

ATTENTION! IMPORTANT:  
use correct tightening torque  
on bolts of shaft clamp  
bushing and gearbox

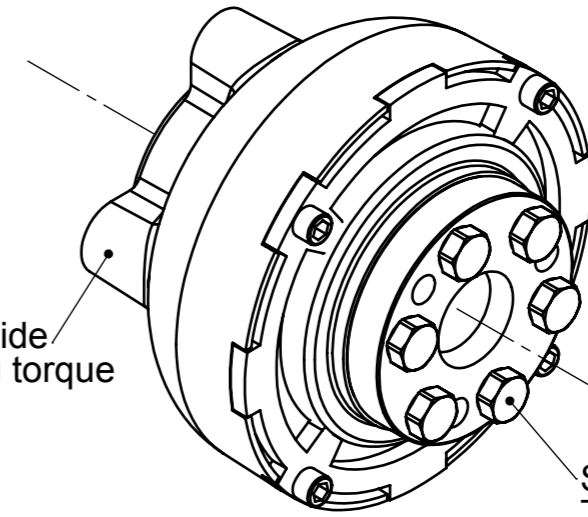

Gearbox side  
Tightening torque  
45 Nm

Shaft clamp bushing  
Tightening torque  
23 Nm

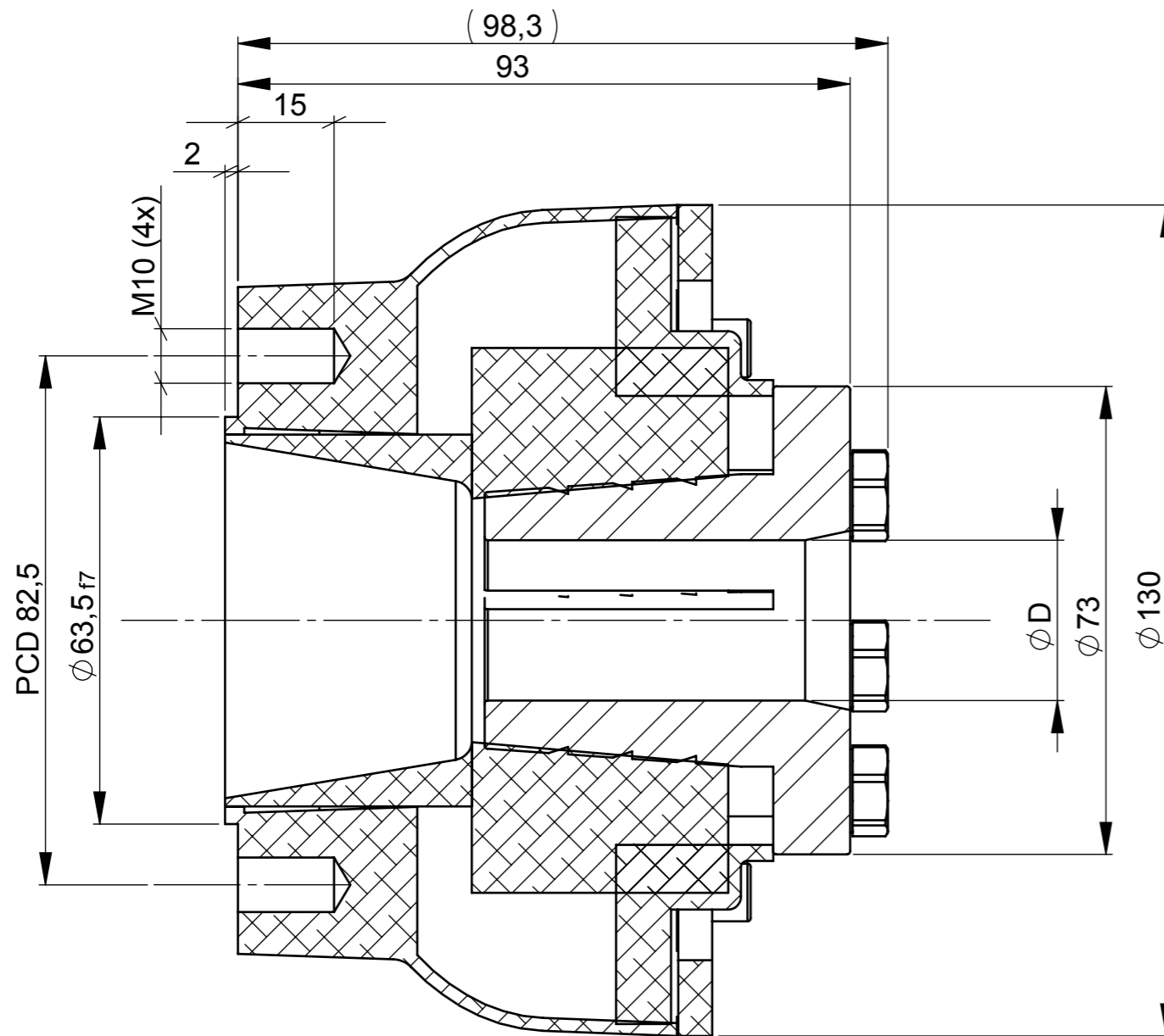

SECTION A-A  
SCALE 1 : 1

Date	Revision	Initials
Description: Flexible coupling $\phi 25 / \phi 30$		Dwg.no.: Flexible coupling
Material:	Weight:	
Scale: 1:2	Proj.:	Date: 31-05-2011
Drawn: D.C.	Checked: JMZ	Size: A3L Dim. in: mm
Product group: Propulsion	Sheet: 1	of: 1



**Craftsman**  
MARINE