

Dimension Including Mosquito Screen

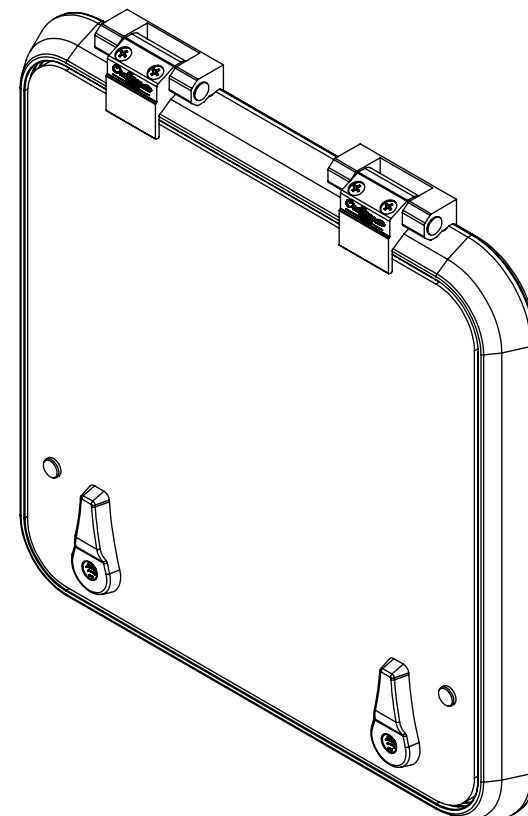
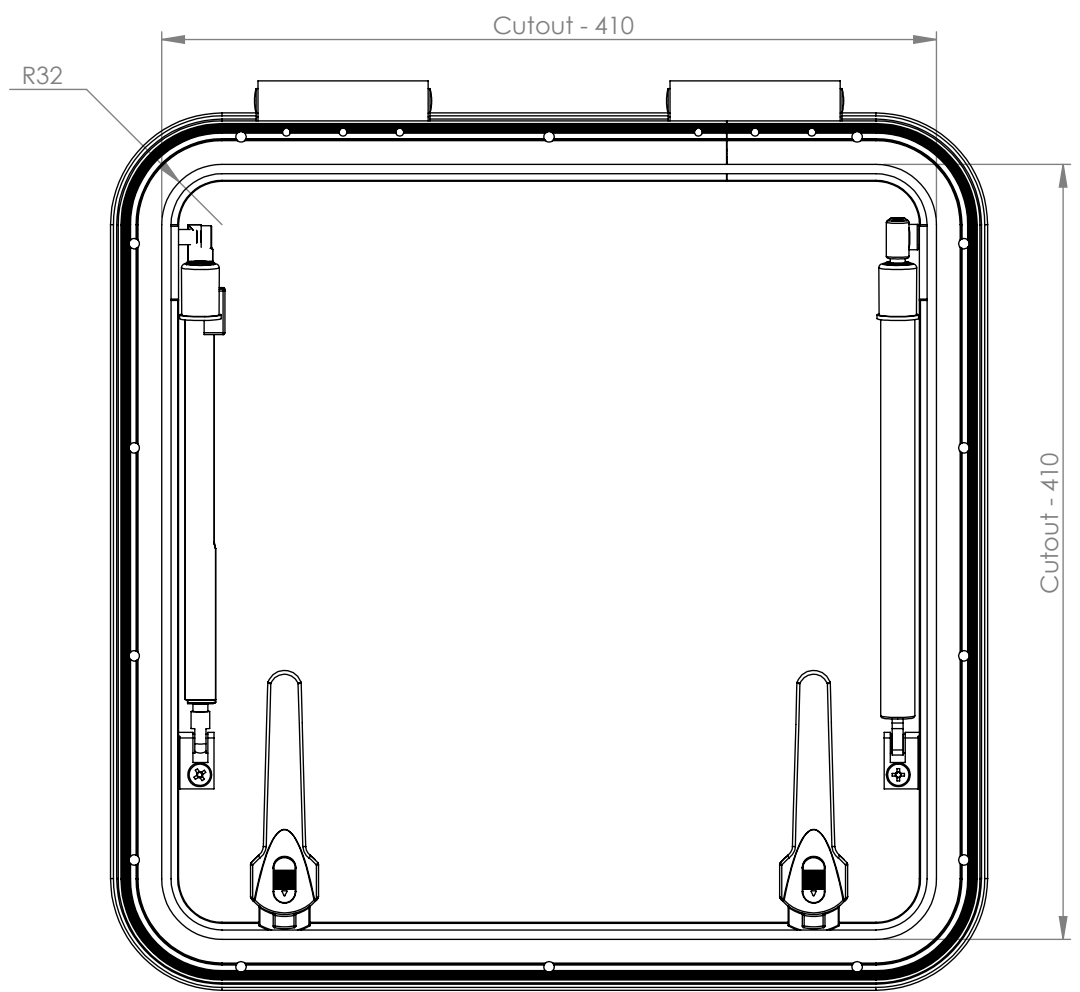

Note : Dimension Tolerance  $\pm 2\text{mm}$

Date	Revision	Description	Initials
------	----------	-------------	----------

<b>Description</b> <b>Assembly Sirius - 410x410 R-32</b>			<b>Dwg.no.</b> <b>FB.010.20050</b>
---	--	--	---------------------------------------



<b>Material:</b>	<b>Heat Treatment:</b>	<b>Weight:</b> gms/Unit
------------------	------------------------	----------------------------

<b>Scale:</b> N.T.S	<b>Proj.:</b>	<b>Date:</b> 11.08.09
---------------------	---------------	-----------------------

<b>Drawn:</b> R.Shankar	<b>Checked:</b>	<b>Size:</b> A3L	<b>Dim. in:</b> mm
-------------------------	-----------------	------------------	--------------------

<b>Product group:</b> Craftsman Marine	<b>Sheet:</b> 1	<b>of:</b> 1
--	-----------------	--------------

**Craftsman**  
MARINE

Visserdijk beneden 70, 3319GV Dordrecht, The Netherlands. Tel: +31 (0)88 0062600, Fax: +31 (0)88 0062601 - info@craftsmanmarine.com - www.craftsmanmarine.com  
 This drawing is the property of Craftsman Marine B.V., Dordrecht. Copyright reserved acc. law. It is not to be copied (in whole or in part) or otherwise disclosed without the written consent of Craftsman Marine B.V.

Surface Finish					
Ra Value $\mu\text{m}$	0.012 / 0.025 / 0.05 / 0.1 / 0.2	0.4 / 0.8	1.6 / 3.2 / 6.3	12.5 / 25 / 50 / 100	
120 to 315: $\pm 0.5$	315 to 1000: $\pm 0.8$		1000 to 2000: $\pm 1.2$		
0 to 6 : $\pm 0.1$	6 to 30 : $\pm 0.2$		30 to 120 : $\pm 0.3$		
General Tolerances where not specified					